

the right freshness

CAREL



humiDisk



T e c h n o l o g y & E v o l u t i o n

For cold rooms and store rooms centrifugal humidifier



humiDisk uses a spinning disk to atomize water.

Very fine droplets are blown into the controlled environment by a built-in fan where they evaporate to humidify and cool the air!

Hygienically safe

- very small water tank, just 0.12lb (55 ml), which is emptied at the end of each cycle;
- very frequent changing of the water, meaning that fresh water is always atomized;
- washing procedure at the start of each cycle (only with humiDisk₆₅ plus CAREL electrical panel).

Powerful and simple

- high atomization capacity, up to 14.3 lb/h (6.5 kg/h);
- works with mains drinking water and water;
- low power consumption: around 75 W per kg/h of output.



Accessories

Humidistat

The simple and low-cost mechanical humidistat can be connected directly to one or more humiDisk units (up to 10 in parallel for the humiDisk₁₀ and just 1 for the humiDisk₆₅).



Control panel humiDisk₆₅ only

The electronic control panel is available in two versions, for managing one or two humidifiers, in parallel. Humidity probe not included, ON/OFF operation.



Applications

cold rooms, stores and maturing rooms for products such as fruit and vegetables, wine cellars (barrel rooms), where low humidity would cause a loss in weight and spoil the products;

paper and printing industries, where the correct level of humidity needs to be maintained in order to avoid alterations in the size of the paper, electrostatic discharges and keep dust levels down;

textile industries, where the right humidity reduces the breakage of the fibers and problems due to dust, while the adiabatic cooling process absorbs the heat generated by the looms.

Technical specifications

models	humiDisk ₆₅	humiDisk ₁₀
Capacity	14.3 lb/h, adjustable from 1.9 to 14.3 lb/h (0.85 to 6.5 kg/h)	2.2 lb/h (1 kg/h) at 230 V 50 Hz 2.6 lb/h (1.2 kg/h) at 110 V 60 Hz
Power supply	230 V, 50 Hz - 110 V, 60 Hz	230 V, 50 Hz - 110 V, 60 Hz
Power input	230 W - (290 W with antifreeze device)	31 W
Air flow-rate	280 m ³ /hour (165 CFM)	80 m ³ /hour (47 CFM)
Water content	0.12lb (0.055 litres)	0.12lb (0.055 litres)
Operating conditions	+34 to +95°F (1T35 °C) WITHOUT antifreeze device, - 0 to 100% RH non-condensing	+34 to +95°F (1T35 °C) - 0 to 100% RH non-condensing
Antifreeze heater	no	no
Electronic board for capacity control	yes	no
Electrical panel with electronic humidistat	yes (optional)	no
Mechanical humidistat	yes (optional)	yes (optional)
Installation accessories	accessories for ceiling and wall-hung installation, supply and drain hoses included.	accessories for ceiling installation INCLUDED. Accessories for wall-hung installation and hoses NOT INCLUDED, available as optionals.
Index of protection	IPX4	IPX4
Supply water pressure	100 to 1000 kPa	100 to 1000 kPa
Water temperature limits	+33.8 °F (+1 °C) to +122 °F (+50 °C)	+33.8 °F (+1 °C) to +122 °F (+50 °C)
Limits in the total hardness of the water (*)(**)	max 30 °FH (max 300 ppm CaCO ₃)	max 30 °FH (max 300 ppm CaCO ₃)
Limits water conductivity (**)	100 to 1200 µS/cm	100 to 1200 µS/cm
Certification	CE and ETL	CE and ETL

(*) not less than 200% of Cl- in mg/l

(**) The quantity and the quality of the minerals dissolved in the water affect the frequency of the routine maintenance operations and the amount of dust generated. For best operation, use water (not softened, as this does not reduce the content of minerals dissolved in the water). At any rate, it is suggested to follow the specifications of the UNI 8884 standard, "Characteristics and treatment of the water in cooling and humidification circuits", conductivity <100 µS/cm; total hardness <5 °FH (50 ppm CaCO₃).

Summary table

Humidifiers

	code	description	notes
USA	UC01001010	centrifugal water spray humidifier - 2.6 lbs/hr - 110V 60Hz	
USA	UC06501010	centrifugal water spray humidifier - 14.3 lbs/hr - 110 V 60 Hz	

Accessories

	code	description	notes
EU/USA	UC10KSSP00	wall-mounting bracket	to be used with humiDisk10
EU/USA	FWH3415000	CAREL standard water supply hose, 4.9 ft, 3/4"	to be used with humiDisk10
EU/USA	UCTS00000	water drain hose	to be used with humiDisk10
EU/USA	UCHUMM0000	mechanical room humidistat, 20 to 90% RH	up to 10 humidisk10 units in parallel

Probes

	code	description	notes
EU/USA	DPWC111000	ambient humidity probe 10 to 90% RH	
EU/USA	DPWC110000	ambient temperature-humidity probe 32 to 122 °F 10 to 90% RH	
EU/USA	DPWC111000	ambient temperature (NTC res.) - humidity probe 32 to 122 °F 10 to 90% RH	
EU/USA	DPPC110000	ambient temperature-humidity probe 32 to 122 °F 10 to 90% RH	
EU/USA	DPPC210000	ambient temperature-humidity probe 14 to 158 °F 0 to 100% RH	

Dimensions (inches)

humiDisk₆₅ - weight 38.8 lbs

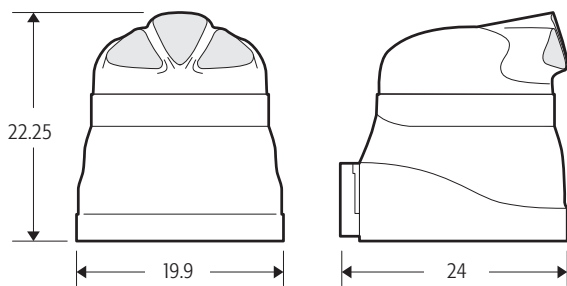

Positioning

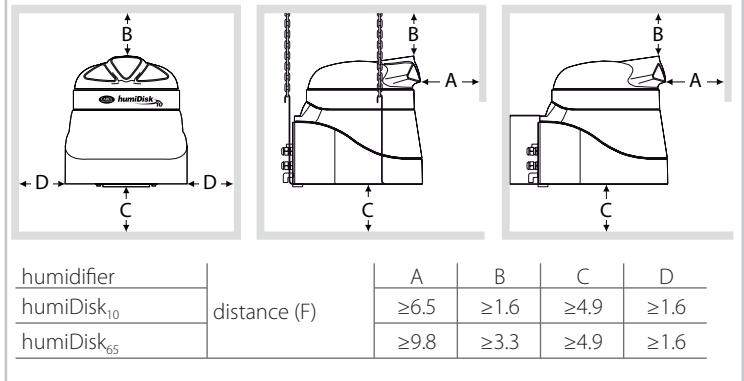

humiDisk₁₀ - weight 9.5 lbs

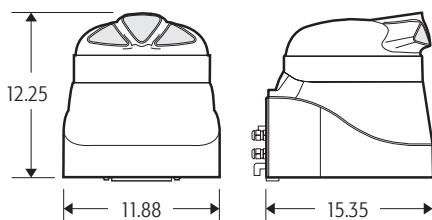

control panel

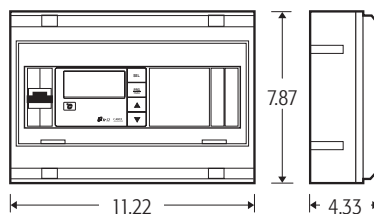

humidistat

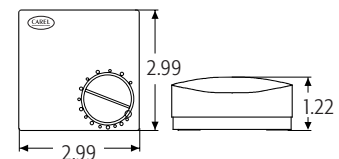

CAREL

CAREL USA
 385 South Oak Street, Manheim, PA 17545
 Tel. (717) 664-0500 - Fax (717) 664-0449
 www.carelusa.com